

案名:

聯絡人:

送貨地址:

本場五金需求:

- 鉸鍊:黑騎士/BLUM/廠牌(有無束)-(自備)
- 滑軌:川湖(三段/座式)/BLUM/廠牌-(自備)
- 櫃體五金:KD組/木樺/活格粒/固隔器/調整腳-(自備)
- 燈具:需求-(自備)
- 吊衣桿:晨曦銀/暗夜灰/一般-(自備)
- 特殊五金:需求-(自備)

下單建議需求:

- AUTO-CAD如下
- 圖面比例-1:20
- 字型/大小:微軟正黑體
數字字型:標註大小3.5
國字字型(圖內):文字大小3.5
(圖外):文字大小4.0
- 建議以線體粗細標準:0.15列印

下單門片-抽頭時:

- 對圖時未告知(不扣縫)或標記於圖面
均依照公司標準扣自然縫

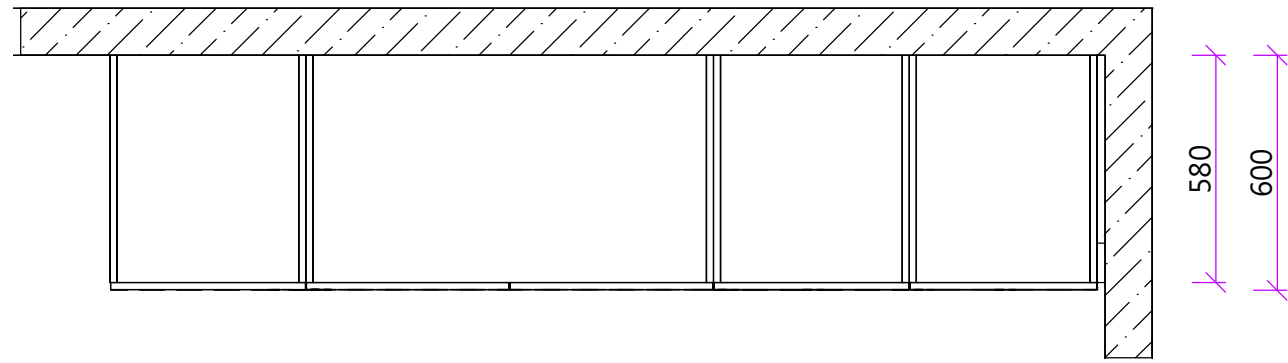

- 本頁特殊五金:需求/自備
- 門片/櫃體:自備
- 以上當頁標註

- 櫃體:110白色
- 門板:125喬木
- 其他:902柚壇.L107皮革灰
- 以上當頁標註

- 1檯面:980*600*18(#L107皮革灰)
 - 2檯面:1040*600*18(#902柚壇)
 - 3假門:627*100*18(#110白色)
 - 4封板:1040*540*8(#110白色)
- 如:圖面物件不多-使用引線注釋即可

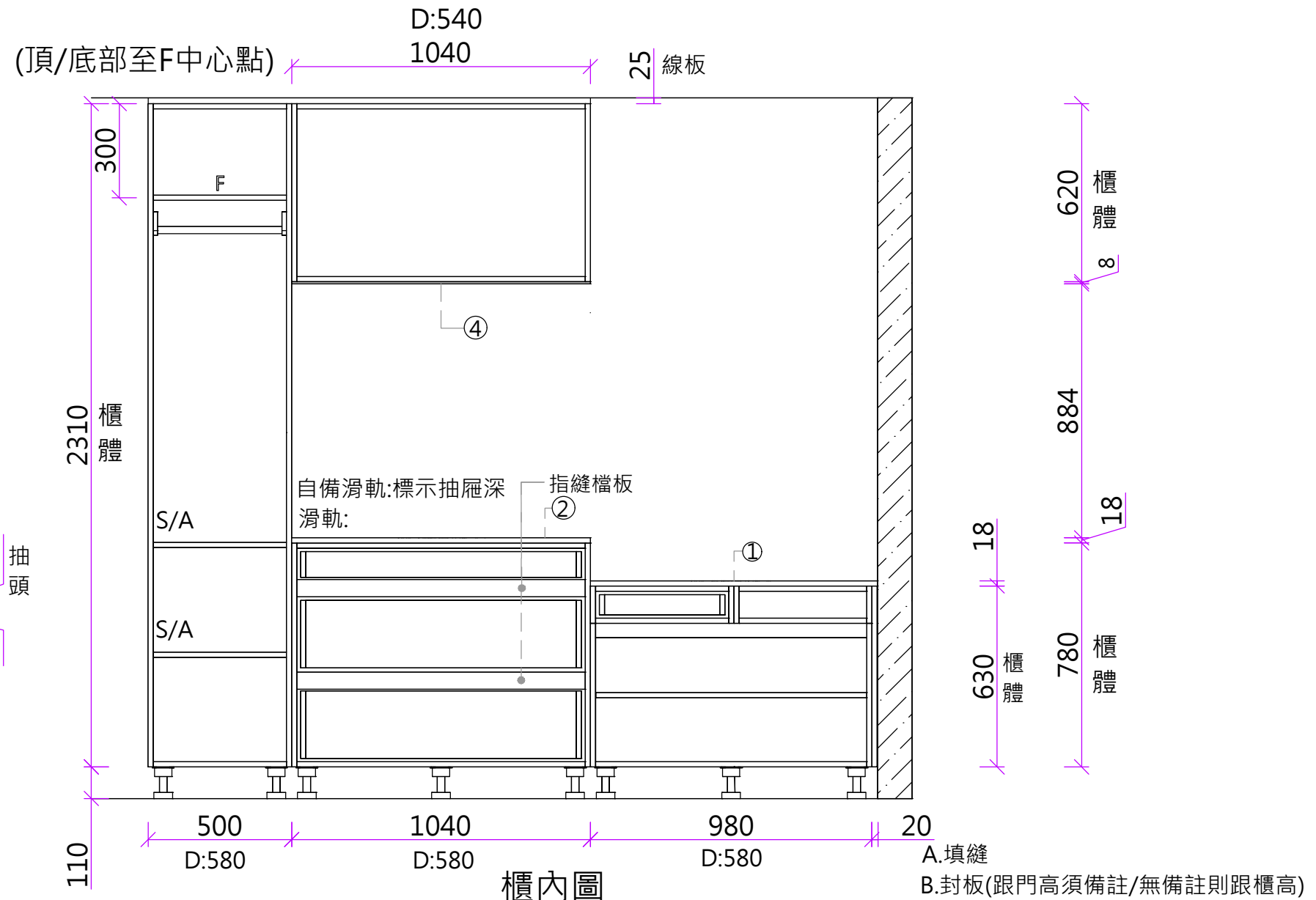
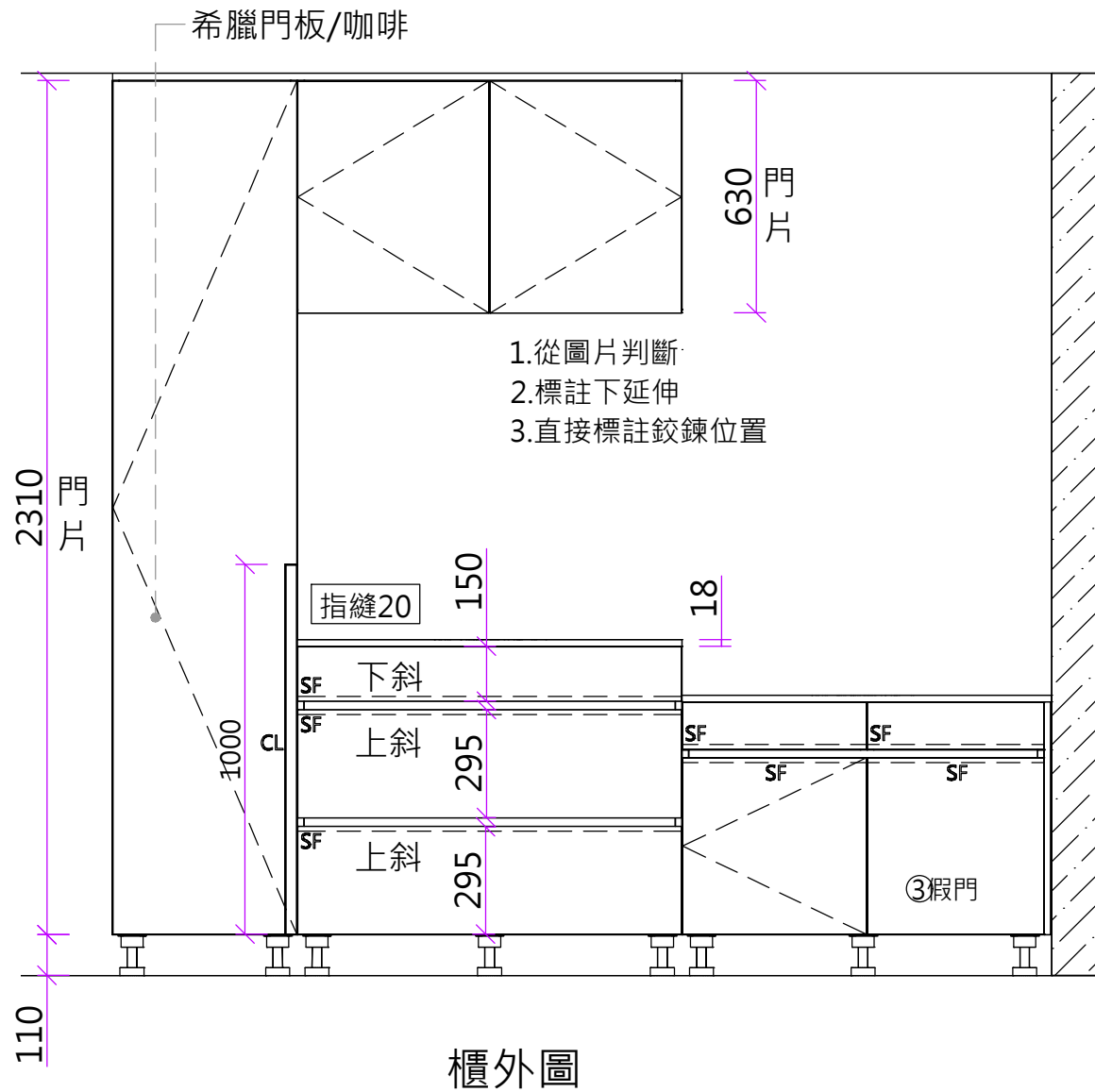

伸保木業股份有限公司
No. 3, Lane 182, Gongye Road, Jongheh Village,
Longjing District, Taichung City 434, Taiwan
TEL : 886-4-26308785 FAX : 886-4-26300480

PROJECT	DESIGNED BY	DRAWN BY	SCALE	UNIT	REV. DATE	DESCRIPTION	APPROVED BY
案名		繪圖員	1:20	mm			
DRAWING NAME	APPROVED BY	CHECKED BY	DATE	DRAWING NO.			
立面			2021/12/02	頁碼 / 總頁數			

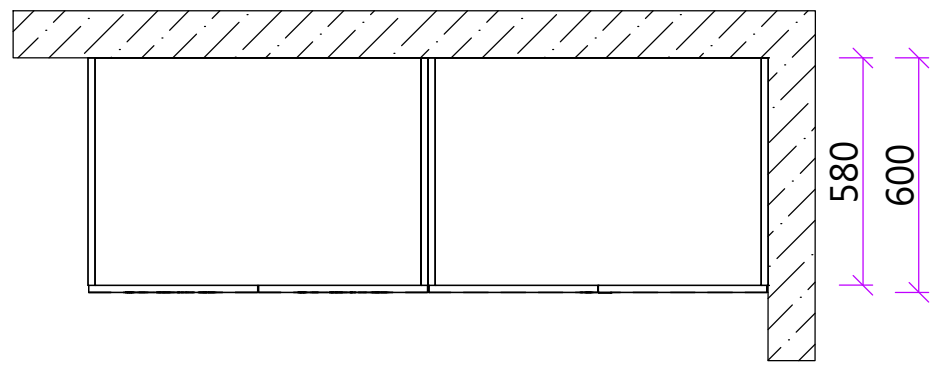

- 特殊加工-ex.燈溝
- 1.現場加工
- 2.文字備註(底板洗溝-離後120+8/D12)
(底板洗溝向上-離前120+8/D12)
- 3.圖示(如下圖)

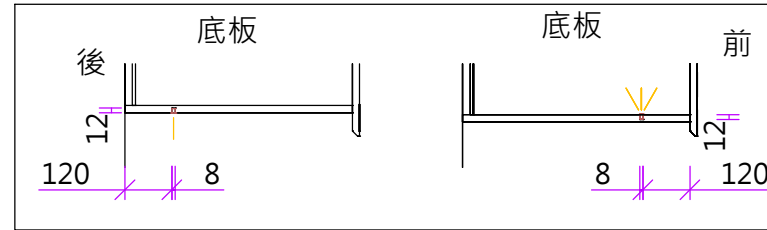

- 櫃體:110白色
- 門板:125喬木
- 其他:L107皮革灰
- 以上當頁標註
- 本頁特殊五金:需求/自備
- 門片/櫃體:自備
- 以上當頁標註

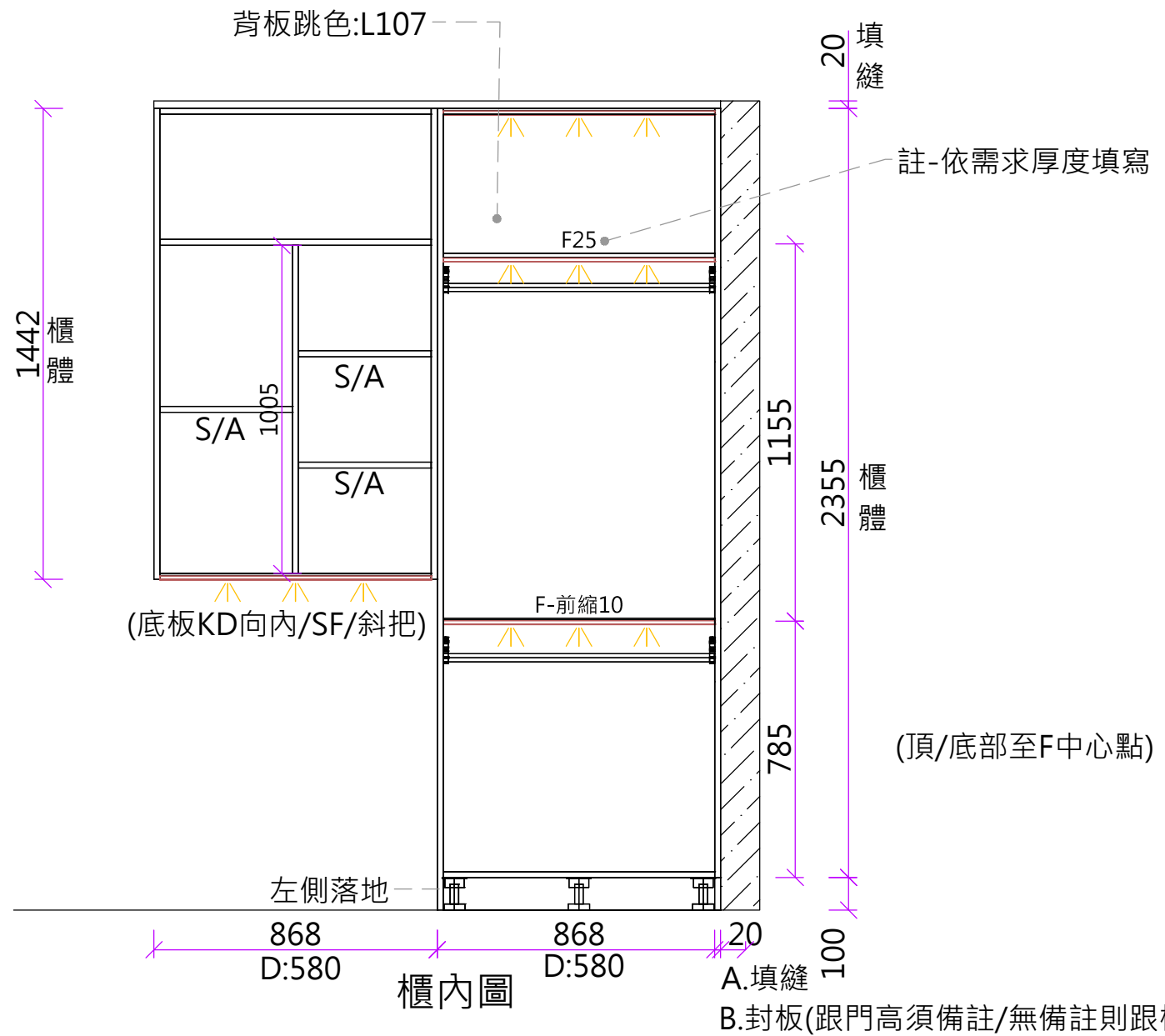
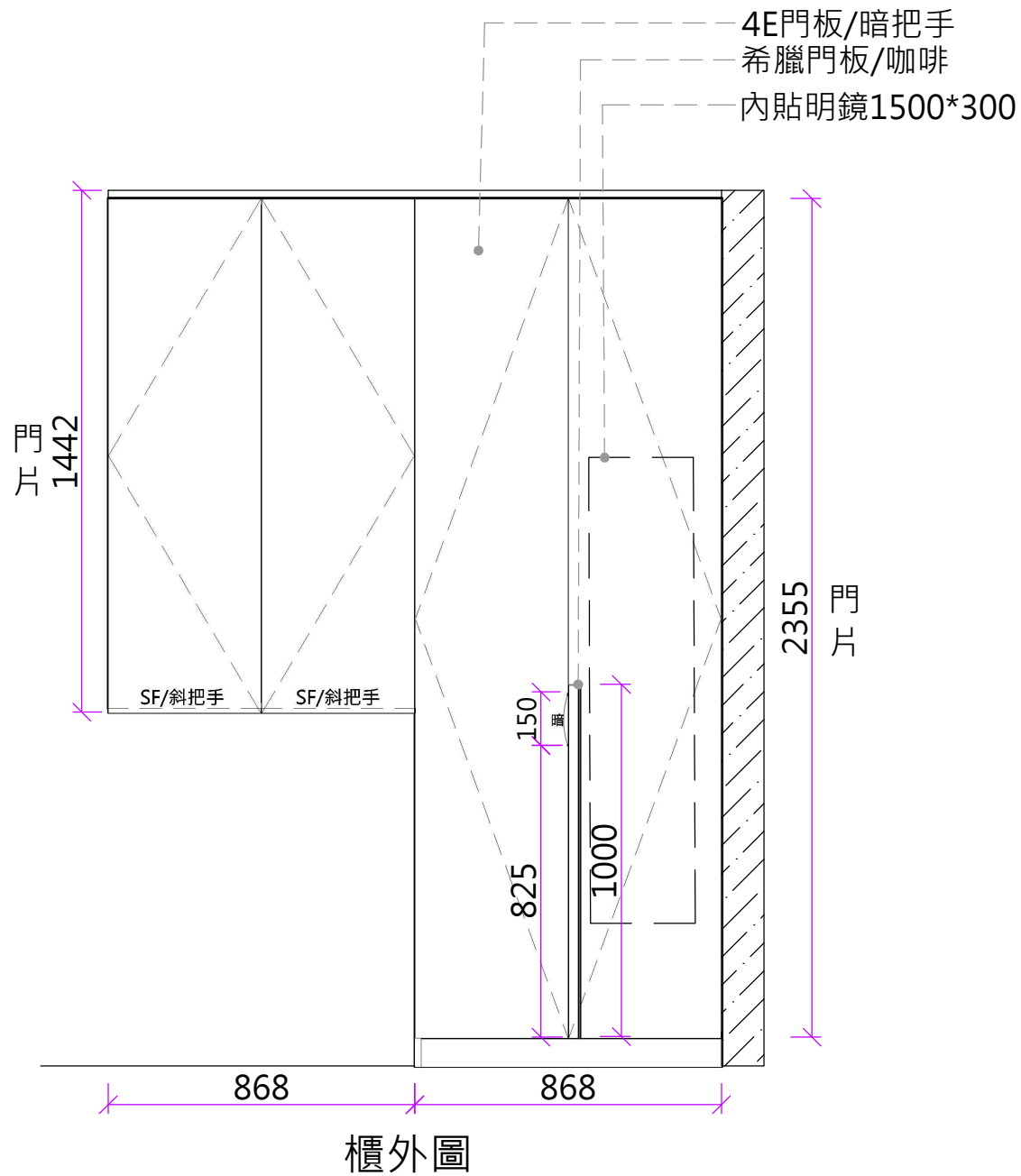

伸保木業股份有限公司
No. 3, Lane 182, Gongye Road, Jongheh Village,
Longjing District, Taichung City 434, Taiwan
TEL : 886-4-26308785 FAX : 886-4-26300480

PROJECT	DESIGNED BY	DRAWN BY	SCALE	UNIT	REV. DATE	DESCRIPTION	APPROVED BY
案名		繪圖員	1:20	mm			
DRAWING NAME	APPROVED BY	CHECKED BY	DATE	DRAWING NO.			
立面			2021/12/02	頁碼 / 總頁數			

- 櫃體:110白色
- 門板:125喬木
- 其他:
- 以上當頁標註

- 本頁特殊五金:入柱鉸鍊/自備
- 門片/櫃體:崁把手自備/工廠洗
- 以上當頁標註

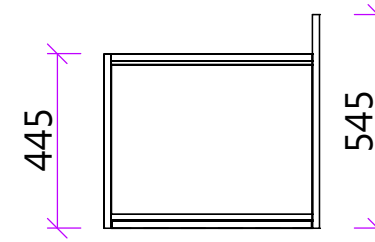
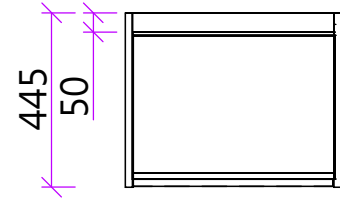

頂底板前縮20

背板離後緣50

右側板後延伸100

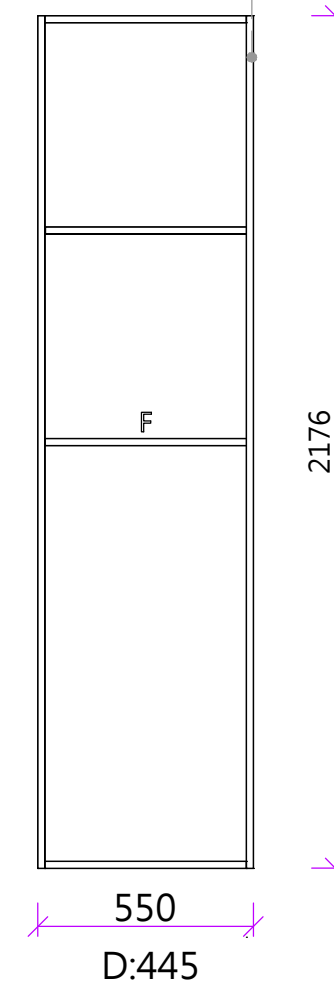
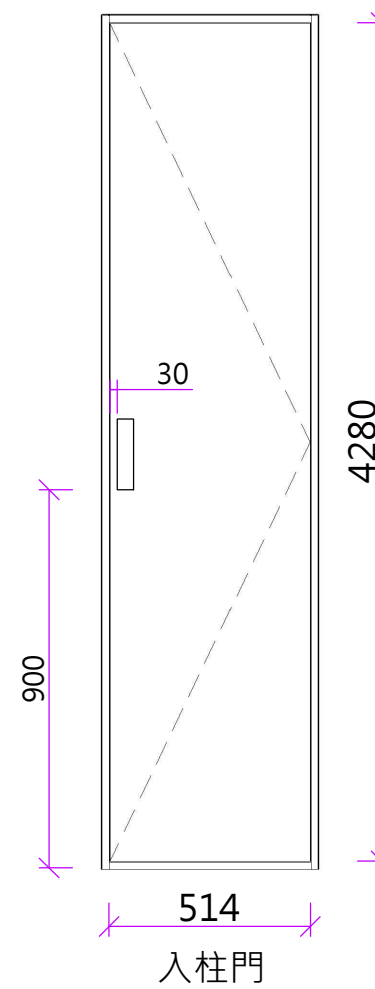
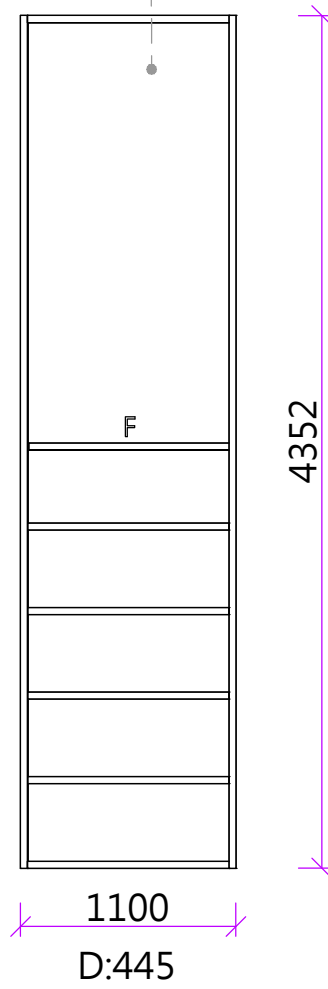
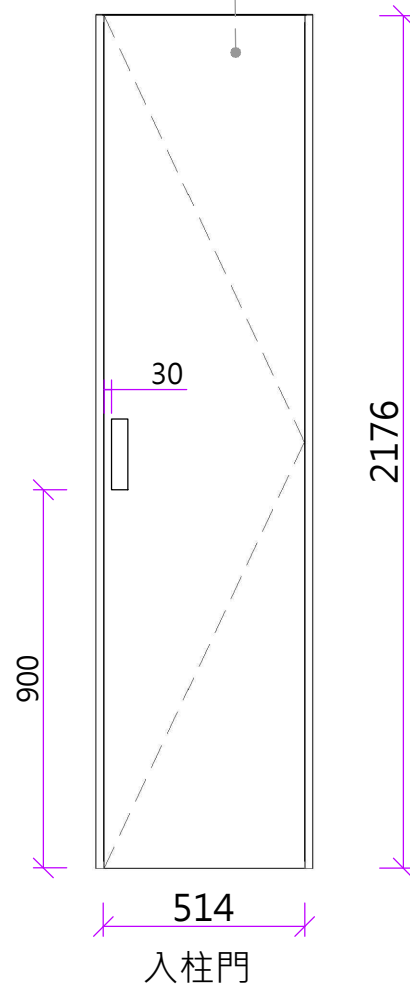

櫃外圖

SHENBAO
INGENUITY. CRAFTSMANSHIP. CONSULTANCY

伸保木業股份有限公司
No. 3, Lane 182, Gongye Road, Jongheh Village,
Longjing District, Taichung City 434, Taiwan
TEL : 886-4-26308785 FAX : 886-4-26300480

PROJECT	DESIGNED BY	DRAWN BY	SCALE	UNIT	REV. DATE	DESCRIPTION	APPROVED BY
案名		繪圖員	1:30	mm			
DRAWING NAME	APPROVED BY	CHECKED BY	DATE	DRAWING NO.			
立面圖			2021/12/02	頁碼 / 總頁數			